



Audible & Visual Signals

STAINLESS STEEL COMBINATION UNITS

WITH ACTIVATION CONTROL

Explosion Proof Sounder/Beacon > Stainless Steel SB125-2, 3 & 4 Series

Product overview

The SB125-2, 3 & 4 combined sounder beacon range has been approved for use in potentially explosive atmospheres and very harsh environmental conditions.

Typical applications are Oil and Gas, On-shore and Offshore, Chemical, Petrochemical, Refineries & Marine locations etc.

The unit incorporates a three stage alarm option with 60 tones to choose from.

The units offer a combined audible & visual warning signal with the option of either a junction box, allowing extra space for ease of installation & final connections. This is particularly helpful if the unit is to be installed into a fire or telecom system where additional cabling is required to monitor external devices or a push button unit for manual activation.

The units are mounted on a heavy duty 316 stainless steel, pre-drilled, mounting plate & the units are pre-wired as standard, so that on the basic model a single input operates both units simultaneously.

Features/Certifications

- Approved by ATEX, IECEx
- CQST (Available on request only)
- ATEX: II 2G Exd IIC T4 - T6 (incorporating IIA & IIB)
- Zones 1, 2, 21 & 22
- Conforms to EN (IEC) 60079-0 EN (IEC) 60079-1 and EN54
- Dustproof & Weatherproof

SB125-2, 3 & 4 Series > Ordering Information

SB125	Combination Type	Combined With (Optional)	Lens Colour	Beacon Type	Power (Xenon)	Power (LED)	Voltage	Duty Label	Tag Label	Lens Guard	Cable Entry	Finish Colour	Telephone Initiated
Follow the chart (right) to generate your part code.	2 = 1xS, 1xB	J = Junction Box	A = Amber	X = Xenon	02 = 2J	05 = 5W	DC 12 ~ 48v	Y = Yes	Y = Yes	Y = Yes	A = M20	RD = Red	Y = Yes
			R = Red		10 = 10J							YW = Yellow	
	3 = 1xS, 2xB	P = Push Button	B = Blue	L = LED	15 = 15J	10 = 10W	AC 100-240v	N = No	N = No	N = No	B = M25	BU = Blue	N = No
			G = Green		20 = 20J							BL = Black	
	4 = 1xS, 3xB		C = Clear									OR = Other	

Note: S= Sounder, B= Beacon

MODEL CONFIGURATOR (By using the table above, complete this box sequence to select your required junction box)

SB125													
Combination Type	Combined With	Lens Colour	Beacon Type	Power (Xenon)	Power (LED)	Voltage	Duty Label	Tag Label	Lens Guard	Cable Entry	Finish Colour	Telephone Initiated	

Note: All customers orders will be confirmed in writing. Care should be taken that the correct code has been ordered as be-spoke manufactured products cannot be returned for exchange or credit later.

Kg 11.9 SB125-2 16.7 SB125-3 22.0 SB125-4	°C -40+70	IP 66	INDUSTRIAL	MARINE	FIRE
APPROVALS and CONFORMITIES					
					STAINLESS STEEL

Explosion Proof Sounder/Beacon > Stainless Steel SB125-2, 3 & 4 Series

General Information

EX CODE:	Ex d IIC T4~ T6 Gb, Ex tb IIIC T135°C~T85°C
CERTIFICATION:	ATEX (Nemko 14 1010X), IECEx (NEM 14.0006X) CQST (Available on request only)
TYPE:	Xenon or LED Audible and Visual Signal Warning Device
SOUNDER:	3 Stage alarm with 60 Selectable tones
POWER RATING:	5-20 Watts Adjustable
SOUND OUTPUT:	Up to 111 dB at 1 metre (+/- 3 dB) *

Xenon Working Status		Xenon - Flashing			
Flash Rate		Selectable from 60-180 Flashes per Minute			
Power Rating	2.5 J (4W) Max	5 J (10W) Max	10 J (15W) Max	15 J (20W) Max	20 J (25W) Max
Effective Candela	67	109	293	395	424

LED Working Status		LED - Flashing / Rotating / Static	
Flash Rate		Selectable from 60-120 Flashes per Minute	
Rotation Rate		Selectable from 60-120 Revolutions per Minute	
Static Mode		Permanently ON (ie Steady)	
Power Rating	5 W	10 W	
Effective Candela	128	312	

MULTIPLYING FACTOR FOR COLOURED LENSES:

Amber x 0.51, Red x 0.15, Blue x 0.12, Green x 0.49, Clear x 1

Mechanical Specifications

MATERIAL:	Enclosure & Bracket: Stainless Steel 316 Lens: Tempered Glass
LENS COLOURS:	Amber, Red, Blue, Green, Clear or Other (specify)
ENCLOSURE COLOUR:	Red (RAL3001), Yellow (RAL1003) Blue (RAL5005), Black (RAL9004)
AMBIENT TEMPERATURE:	-40 to +70
HUMIDITY:	≤ 95% RH
WEIGHT:	SB125-2: 11.9 Kg / 26.2 lb, SB125-3: 16.7 Kg / 37 lb SB125-4: 22 Kg / 49 lb
DIMENSIONS:	See outline drawings and table for dimensions.
INGRESS PROTECTION:	IP 66
Electrical Specifications	
POWER SUPPLY:	≤48v Dc or 100-240v Ac (50/60 Hz), Beacon: ≤25W, Sounder: ≤20W
TERMINATION:	Accepts upto ≤ 2.5mm ² incorporating rising clamp protectors
CABLE ENTRY:	2 x M20 or M25. For 1/2" or 3/4"NPT requirements, male female adapter glands are available. Contact sales dept for further part codes.
CURRENT CONSUMPTION:	Sounder 250 mA - 1500 mA (Adjustable by tone selection)

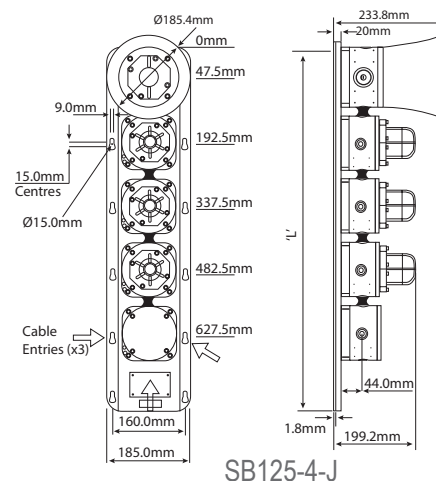

SB125-4-J

Combination	No Key Slots	'L'
SB125-2	6	400.0
SB125-3 (2J or P)	8	545.0
SB125-4 (3J or P)	8	690.0
SB125-5 (4J or P)	10	835.0

Accessories

50023:	Cage Guard (Stainless Steel)
50210:	M20 E1EX Stainless Steel Gland (Multi Armour Cone) Atex Cat 2 & 3, EExde IIC 2 GD Cable ID 11 - 15.5mm OD 14.5 - 21mm Gland for Multi Armoured Cable *
50211:	M20 A2EX Stainless Steel Gland Atex Cat 2 & 3, EExde IIC 2 GD Cable OD 11 - 15.5mm Gland for Unarmoured Cable *
50212:	M20 E1EX-QS Stainless Steel Gland (Ex d IIC, Ex e IIC, Ex nR IIC, Ex tb IIIC) Cable OD 14.5 - 20.5mm Barrier Gland for Steel and Aluminium Armoured Cable *
50213:	M20 A2EX Quick Stop Stainless Steel Gland (Ex d IIC, Ex nR IIC, Ex tb IIC) Cable OD 9 - 15mm Barrier Gland for Unarmoured Cable *
50214:	M20 Stainless Steel Stopping Plug Atex EExde I/IIC Standard M20 Blanking Plug
50221:	Epoxy Minute Adhesive 24m/l tube One tube sufficient for five barrier glands
* 15mm Note:	Thread length for Stainless Steel products M25 options available for the above

SB125-2, 3 & 4 Series > Working Current

Power Consumption: Sounder: 5-20W & LED: 5W

Xenon	2.5 Joule	5 Joule	10 Joule	15 Joule	20 Joule
	4 W (Max)	10 W (Max)	15 W (Max)	20 W (Max)	25 W (Max)

Working Current: Sounder: 250 mA - 1500 mA & LED: 220 mA (Max)

Xenon	2.5 Joule	5 Joule	10 Joule	15 Joule	20 Joule
	160 mA	320 mA	650 mA	1A (Max)	1.4A (Max)

LED

POWER	12v Dc	24v Dc	48v Dc	110v Ac	220v Ac
5 W	530 mA	260 mA	120 mA	80 mA	40 mA
10 W	1100 mA	530 mA	240 mA	160 mA	80 mA