

## TECHNICAL DATA SHEET

The LED-TL beacons have been designed to offer low maintenance, long life and a cost effective solution for car park management, factory traffic control, automated gate and door control systems. The modules use a 36 SMT LED array that fits in the lens and offers a static light when energised.

Code No:	Voltage:	Light Source:	Current:
<b>Double Assembly Unit - Red &amp; Green Lens</b>			
LED-TL-01-02-04	8-20v Ac/Dc ~	36 SMT LEDs	480mA @ 12v Dc
LED-TL-02-02-04	20-30v Ac/Dc ~	36 SMT LEDs	240mA @ 24v Dc
LED-TL-03-02-04	35-85v Ac/Dc ~	36 SMT LEDs	155mA @ 48v Dc
LED-TL-05-02-04	85-380v Dc --- 85-280v Ac ~	36 SMT LEDs	70mA @ 230v Ac
<b>Triple Assembly Unit - Red, Amber &amp; Green Lens</b>			
LED-TL-01-02-01-04	8-20v Ac/Dc ~	36 SMT LEDs	720mA @ 12v Dc
LED-TL-02-02-01-04	20-30v Ac/Dc ~	36 SMT LEDs	360mA @ 24v Dc
LED-TL-03-02-01-04	35-85v Ac/Dc ~	36 SMT LEDs	230mA @ 48v Dc
LED-TL-05-02-01-04	85-380v Dc --- 85-280v Ac ~	36 SMT LEDs	110mA @ 230v Ac

### Key Features Include:

- Terminal block accepts up to 2.5mm<sup>2</sup> (14-22 AWG) stranded core with 4mm cut back
- Suitable for wall mounting
- 120° prime light output above the vertical axis
- 180° degree of angle movement, optimising the visual indication position
- Ingress Protection: Weatherproof to IP65
- Operating Temperature Range: -25 + 55°c
- Enclosure Materials: UV Stable Polycarbonate Lens & Shroud  
UV Stable ABS Base
- AC Supply: 50/60 Hz



## INSTALLATION & TECHNICAL INFORMATION

PLEASE READ PRIOR TO INSTALLATION



### LED-TL Factory Assembled Series - (LED Array)

VISUAL SIGNALLING DEVICES

APPROVED AND  
CONFORMITIES



## INSTALLATION DATA SHEET

Position the bracket on the mounting surface, mark and drill appropriate holes for the fixing screws, not supplied. The brackets are designed with a key hole slot at the top and an elongated one at the bottom (see diagram 1) and then securely fix the traffic light assembly in place.

Once the traffic light assembly is firmly secured remove the 2 screws retaining the shroud and lens from the green TL module, remove shroud and carefully pull lens from back box to show termination block in the base of the unit. The control wires are colour coordinated with the lens colours and terminate in this block.

Insert the power/control cable through the M16 cable gland (4.5 – 10mm max cable diameter) attached to the bottom of the green module base and connect to the termination block as required (see diagram 2)

Ensure 'O' rings are in place on bases. Line up the lens holes with those in the base and carefully snap the lens into position, taking care that the power cables do not foul PCB components. Fit the shrouds over the lenses and secure in position with the screws.

By slackening off the top & bottom M16 glands the traffic lights can now be rotated through 180 degrees to optimise the best viewing position.

Once this has been selected gently tighten up the two M16 glands.

### General

- Installation must be carried out in accordance with the latest codes of practice and regulations by a qualified engineer.
- Ensure power source is disconnected prior to installation or maintenance to avoid danger of electrical shock.
- Do not handle internal electrical components whilst wiring up.
- Environmental exposure conditions during installation should be dry, moist or wet conditions should be avoided.
- The lens material of the beacon is VO rated UV stable polycarbonate plastic. Do not clean with petroleum based cleaners.
- Avoid mounting the beacon where it will be subject to excessive vibration.

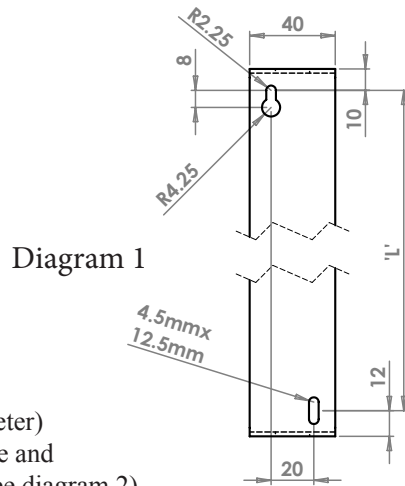

Diagram 1

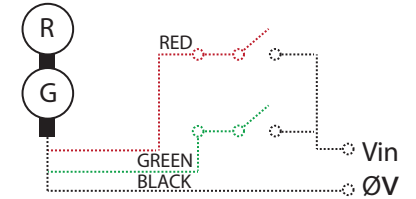
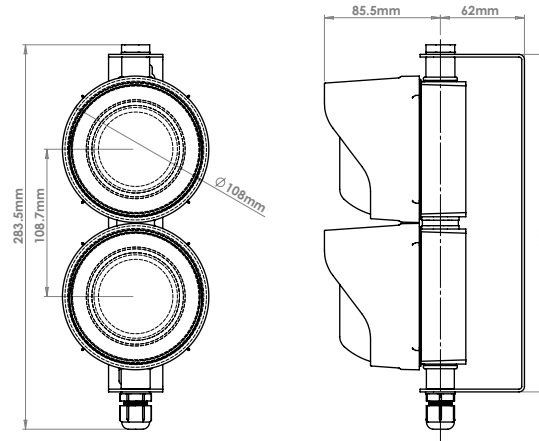
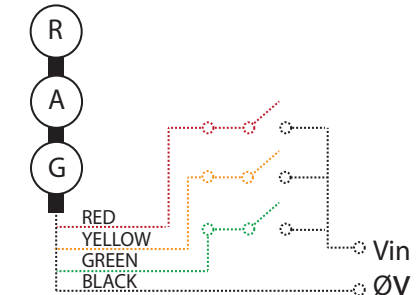
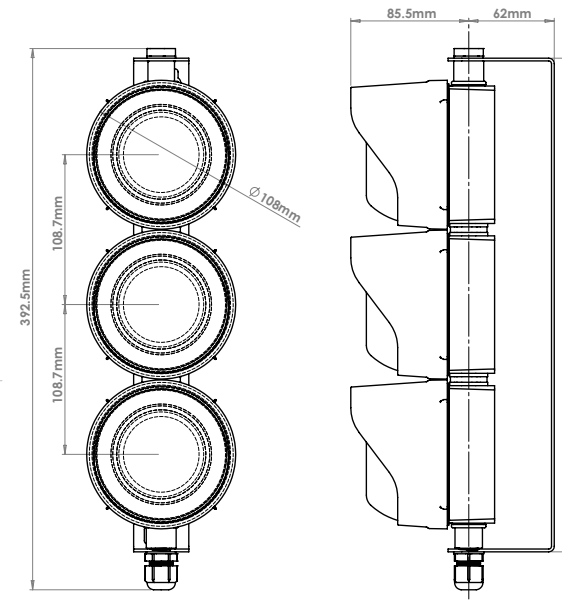

Diagram 2

## Triple Traffic Light Bracket Mounted



NOTE: For 48v DC Voltage Supply and above, reverse the polarity of "0v and +" for the PCB connections to allow for use on Direct Current supply.