

The gland accessories below offer a wide selection to cover most Ex environments

Gland and Plug Options	
50200: M20 E1EX Nickel Plated Brass Gland	50210: M20 E1EX Stainless Steel Gland
50201: M20 A2EX Nickel Plated Brass Gland	50211: M20 A2EX Stainless Steel Gland
50202: M20 E1EX-QS Nickel Plated Brass Gland	50212: M20 E1EX-QS Stainless Steel Gland
50203: M20 A2EX Quick Stop Nickel	50213: M20 A2EX Quick Stop
50204: M20 Nickel Plated Brass Stopping Plug	50214: M20 Stainless Steel Stopping Plug

9.0 End of Line Monitoring

An End of Line monitoring Diode or an End of Line monitoring Resistor can be connected across the 24V+ and 0 terminals. Resistor values for the End of Line will be determined by the customer with a minimum value of 1.2kΩ

10.0 Maintenance

Little or no maintenance is required during the normal working life of the product. The Moflash Exd enclosures are resistant to most acids, alkalis and chemicals and have been designed to withstand severe weather conditions. However it is suggested that to avoid the possibility of a potential electrostatic charge build up, the exterior of the product is periodically wiped down with a clean damp cloth. At this point a visual inspection is recommended to ensure that the product is in good working order and no damage has been sustained during its normal operation.

11.0 Conditions for Safe Usage

i) This apparatus is suitable to be used only in ambient temperature as stated below:

Type	Ambient Temp
SD150	-40°C to +70°C

ii) Do not paint or change the surface finish of the unit. The coating applied by the manufacturer is Anti-Static & UV Stable.

Specific Condition of Use

Repairs of the flameproof joints must be made in compliance with the structural specifications provided by the manufacturer. Repairs must not be made on the basis of values specified in tables 1 and 2 of EN/IEC 60079-1”.

Contact Moflash Signalling Ltd for further information.



INSTALLATION & TECHNICAL INFORMATION

PLEASE READ PRIOR TO INSTALLATION



SD150 Series - (Explosion Proof Sounder)

Glass Reinforced Polyester

AUDIBLE SIGNALLING DEVICE

APPROVALS AND CONFORMITIES



Website: www.moflash.com

Email: technical@moflash.co.uk

1.0 Introduction

The SD150 Explosion Proof range is certified for use and installation in Zone 1 and Zone 2 with gas groups IIA, IIB, IIC, also Zones 21 and 22 for Dust. The unit carries a temperature classification of T4~T6. It especially applies to Oil & Gas, Offshore Platform, Chemical, Petrochemical, Refinery and Marine Industries etc. Enclosure material is UV and corrosion resistance GRP (Glass Reinforced Polyester). The sounder has 4 stage alarm tones which can be sent out. 60 tones are selectable. Tone can be pre-set during installation.

2.0 Explosion Proof Labelling

All products have a rating label with the following important information:

Product order no:

eg SD1501BDCNNAR (Refer to the datasheet for product order selection)

Input voltage: 12-48v DC or 100-240v AC (50/60 Hz), ≤20W

Code: Ex d IIC T4~ T6 Gb, Ex tb IIIC T135°C~T85°C IP66

Nemko ATEX Certificate No: Nemko 14 ATEX 1009X

ATEX Mark: 

IECEX Certificate: IECEX-NEM 14.0005X

Gas Group and Category: II 2GD

CE Mark: Mark No: 0891

Warning: **DO NOT OPEN WHEN AN EXPLOSIVE GAS ATMOSPHERE IS PRESENT**

Finished product serial no (Include date of construction): ie. SD150-0201080001
SD150-GRP Sounder, Day-02, Month-01, Year-08, Product Serial Number-0001

3.0 Type Approval Standard

The Moflash product range all have an EC Type Examination Certificate issued by Nemko and have been approved to the following standards:

EN 60079-0:2012 (IEC 60079-0:2011)
 EN-60079-1:2007 (IEC 60079-1:2007)
 EN 60079-31:2009 (IEC 60079-31:2008)

7.0 Alarm Stages

The alarm stages are set as follows:

Stage	Apply Power To	Termination Connection	Tone
1	L & N	-	No sound
2	L & N	S0 to S1 (Factory pre-set)	Set by DIP SW1
3	L & N	S0 to S2	Set by DIP SW2
4	L & N	S0 to S1 & S2	Set by DIP SW3

Refer to Tone Selection Sheet ref: S00526 for Tone Selection and Volume Control.

Sound Pause Option

Briefly close the loop between ‘**S0 – Dly**’ for 1 second minimum each time to give the required pause interval. The sound automatically restarts at the end of the interval.

No of times	Pause Interval
1	1 minute
2	5 minute
3	10 minutes - Closing the loop again for 1 second during this interval automatically restores the sound.

8.0 Cable Glands

Only cable glands approved for Exd applications can be used with Moflash Explosion Proof Products, these must be suitable for the type of cable being used and also meet the requirements of the Exd flameproof installation standard EN 60079-14.

SAFETY WARNING

If units are used at high ambient temperatures, i.e. over +40°C then the cable entry temperature may exceed +70°C and therefore suitable heat resisting cable glands must be used, with a rated service temperature of at least 95°C.

If a high IP (Ingress Protection) rating is required, a suitable sealing washer must be fitted under the cable gland. Any unused cable entry holes must be closed with an Exd flameproof blanking plug, which must be suitably approved for the installation requirements.

4.0 Zones, Gas Group, Category and Temperature Classification

The SD150 series products have been certified Ex d IIC T4~T6.
This means that the units can be installed in locations with the following conditions:

Area Classification

Zone 1: Explosive gas air mixture likely to occur in normal operation.

Zone 2: Explosive gas air mixture not likely to occur, and if it does, it will only exist for a short time.

Gas Groupings

IIA Propane Group, IIB Ethylene Group, IIC Hydrogen and Acetylene

Zone 21: Explosive dust air mixture likely to occur in normal operation.

Zone 22: Explosive dust air mixture not likely to occur, and if it does, it will only exist for a short time.

Equipment Category: 2GD **Temperature Range:** $-40^{\circ}\text{C} < T_a < 70^{\circ}\text{C}$

5.0 Installation

General Requirement

The product must be installed in accordance with the latest EN60079-0 and EN60079-1 specification or the equivalent IEC specification. Product installation must be carried out in accordance with any local codes that may apply and should only be carried out by a competent electrical engineer.

Location

The location of the unit should be chosen with due regard to the area over which the warning signal must be audible. The unit should only be fixed to services that can support the weight of the unit.

Mounting (Bracket Mounting)

The unit mounts via a 'U' shaped stainless steel bracket by using one 12mm diameter and two 8.5mm diameter bolt holes in the centre of the bracket (see picture 1). The alignment and positions can be adjusted by loosening the two M8 screws, which fastened the stainless steel bracket to the sounder. The sounder should be positioned such that dust, debris or water cannot enter into the horn opening.

Product installation must be carried out in accordance with any local codes that may apply and should only be carried out by a competent electrical engineer.

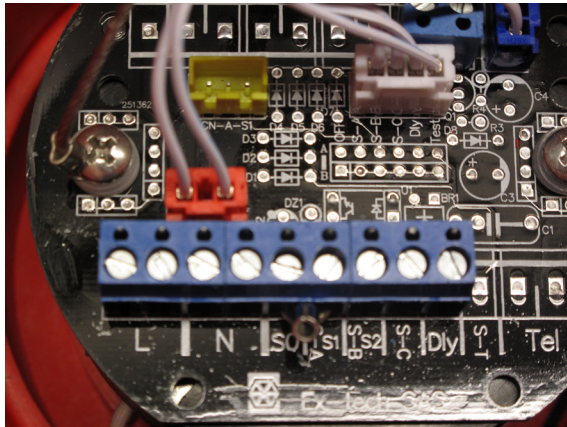

Picture 1

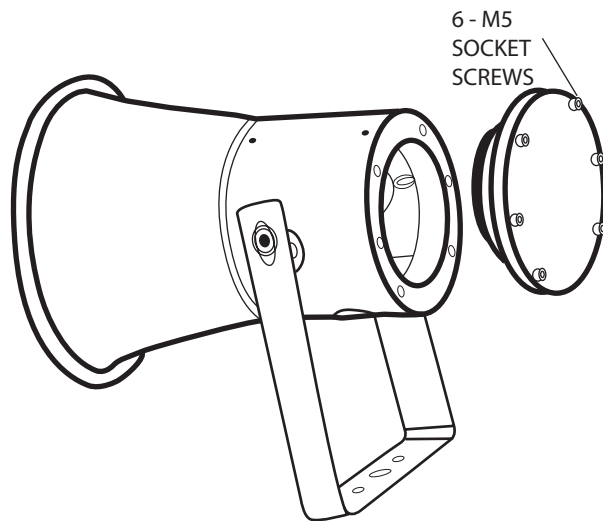

Diagram 2

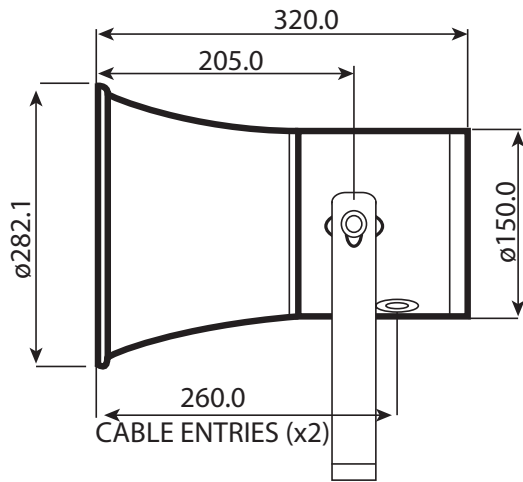
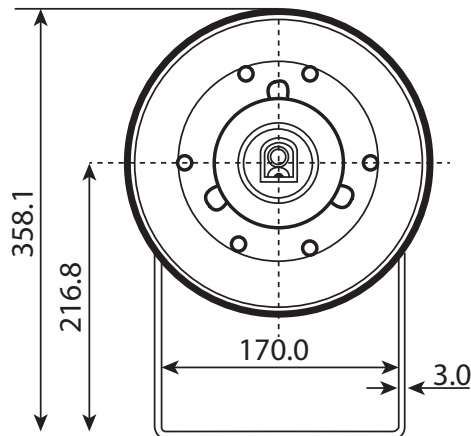
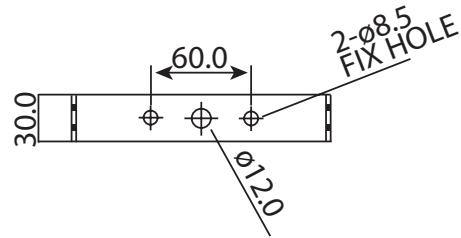

Diagram 1



6.0 Wiring

General Requirement

Moflash recommends that all cables and cores should be fully identified (suggest using cable from 2.0 to 2.5 mm²). Ensure that all nuts, bolts and screws are secured. Ensure that only the right and certified cable glands are used and earthed correctly. Ensure that only the right and certified stopping plugs are used to blank off unused gland entry points. In order to maintain the IP rating of the product, we recommend SS316L for this application.

Cable connection

The cable connection is to terminals on the pcb located in the flameproof enclosure of the sounder. Cable connection should be carried out in accordance with relevant technical requirement (see picture 1).

For **AC supply** - connect to terminals marked 'L' & 'N'.
Terminals provide loop in loop out facility.

For **DC supply** - connect '+' to 'L' and '-' (0v) to 'N'.

Alarm stages - terminals 'S0' (common) 'S1 & S2' (refer to table overleaf).

Do not connect Ac or Dc to terminals S0, S1,S2 & D

Removal of End Cover

Unscrew the six (6) M5 retained hex socket head screws (see diagram 2). Twist the cover gently clockwise and anti-clockwise, whilst pulling away from the body, keeping the cover parallel to the body until it comes free. This will allow the cover to hang on its retaining strap.

Before replacing the cover, check the flameproof joints are clean and not damaged, the gasket is retained in its groove.

Caution: Before removing the cover ensure the power to the sounder is isolated.