

Visual Signals XENON

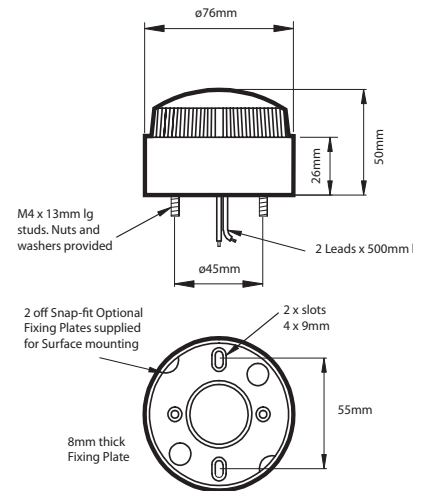

BEACONS



Industrial Xenon Beacons > X80 Series

Product overview

The X80 Series incorporates a discharge capacitor and convertor circuit to ignite xenon gas inside a glass tube, resulting in a flash of light. This beacon offers an economic solution for general signalling applications where local

signal indication is required. The beacons are fully assembled and ready for immediate installation. The unit offers two mounting options, either stud mount or surface mounting using the two piece fixing plate supplied. One plate is fixed to the appropriate surface the other to the beacon, the two plates then 'Snap Fit' together.

Features

- Continuously rated
- Wide operating voltage
- Energy efficient
- 180° visibility
- Economical
- IP67

Material

- UV Stable Polycarbonate Lens
- UV Stable Polycarbonate Base

Code No:	Voltage:	Light Source:	Current:
X80-01	24v Dc ---	Xenon 0.30 J	40 mA
X80-02	10-100v Dc --- 20-72v Ac ~	Xenon 2.0 J	110 mA # at 24v Dc
X80-04	85-265v Ac ~	Xenon 2.0 J	50 mA # at 230v Ac



Kg 0.13

°C -20+55

IP 67

FPM 60/65

INDUSTRIAL

FIRE

APPROVED AND CONFORMITIES



ADD THE FOLLOWING LENS CODES TO THE PRODUCT WHEN ORDERING

01 02 03 04 05