



Audible Signals EXPLOSION PROOF BEACONS

Explosion Proof Audible Sounders > EAE Series

Product overview

Suitable for general signalling duties, their robust construction makes installation in the harshest of environments possible. Additional features include automatic synchronisation on multi-beacon systems and stainless steel guard as standard.

The enclosures are manufactured from corrosion proof, marine grade copper free LM6 aluminium which is phosphated and powder coated. All models have two M20 cable entries and large termination areas.

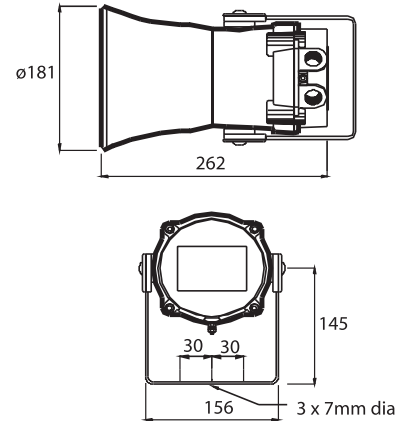

Features

Rated for Category 1 use (formerly Zone 1 & 2)

ATEX approved

 II 2 G EExd IIC T4

117dB @ 1m

2 x 20mm cable entries

4mm terminals for ease of connection

IP66, 67

Material

Marine Grade LM6 Aluminium

Code No:	Voltage:	Current:
EAE100-24	24v Dc ---	250 mA
EAE100-115	115v Ac ~	110 mA
EAE100-230	230v Ac ~	56 mA



Kg 3.40 Ac
3.20 Dc

 °C -50+55

IP 66, 67

dB 117

 **EXPLOSION PROOF**

 **MARINE**

APPROVED AND CONFORMITIES



 **INDUSTRIAL**