

INDUSTRIAL BUZZERS

ACOUSTIC

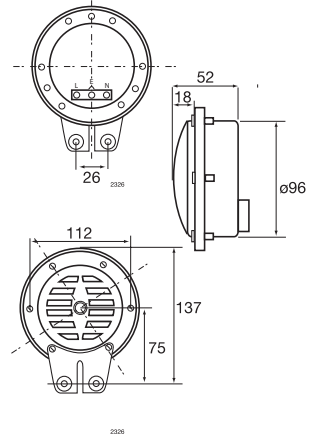

Acoustic Signals Industrial Buzzers

> AE95 Series

Product overview

The AE95 is a medium output low frequency mechanical buzzer. The IP protection can be increased to IP65 by the use of the optional weatherproof back box.

The AE95 is suitable for a wide range of applications including fork lift trucks, emergency alarms, process control alarms and for mechanical handling machinery.

Features

- Industrial buzzer
- Wide voltage range
- Low frequency tone
- 15 minute rating
- Rugged construction
- 115dB @ 1 m
- IP53 (IP65 with back box)

Material

Mild Steel

Code No:	Voltage:	Frequency:	Current:
AE95-05	24/48v Ac/Dc~	335 Hz	0.8 A
AE95-06	115/230v Ac/Dc~	335 Hz	0.4/0.2 A
AE95-BB	Weatherproof back box •		



Kg 0.68

50/60 **Hz**

°C -20+66

IP 53/65 •

dB 115

ON 15 MINS
OFF 1 MINS

APPROVED AND
CONFORMITIES



INDUSTRIAL